

保密等级：机密

SPECIFICATION

产品规格书

SKI.W800DWU. 1 A22242

IEEE 802.11b/g/n/ax 1T1R USB Wi-Fi Module

Approved by Shikun		
Checked by 审核	Rechecked by 复审	Approved by 批准
陈铭	陈琨	

Please send the original back to us after you have approved and signed.

客户承认签章后敬请寄回正本一份。

Approved by customer		
Comments 确认意见	Approved by 批准签字	Company's seal 盖章
Customer's Name:		

REVISION HISTORY

VERSION	DATE	BOARD ID	PAGE	DESCRIPTION	AUTHOR
V0	2022.07.12	SKI.W800DWU.1	ALL	First Issued	Chenming

Content

1. Introduction (简介)	1
2. Features (特性)	1
3. Block Diagram (结构框图)	2
4. Package Outline and Mounting (外形及安装尺寸)	2
5. Pin Definition (引脚定义)	3
6. Product Pictures (实物图片)	3
7. Key Materials (关键物料)	4
8. General Requirements (一般要求)	4
9. Electrical Characteristics (电气特性)	4
9.1 IEEE 802.11b Section	5
9.2 IEEE 802.11g Section	5
9.3 IEEE 802.11n HT20/40 Section(2.4GHz)	6
9.4 IEEE 802.11ax HE20/40 Section(2.4GHz)	7
10. Reference Design (参考设计)	8
11. Mechanical, Environmental and Reliability Tests (机械、环境和可靠性测试)	9
12. Package (包装)	10
13. Storage and Production (存储、生产)	11
13.1 Storage requirements (存储要求)	11
13.2 Production parameters (生产参数)	12

1. Introduction (简介)

SKI.W800DWU.1 is based on AICSEMI AIC8800DW, complied with IEEE 802.11b/g/n /ax from 2.4-2.5GHz.

The HW architecture for the module is shown in Figure 1. It combines a WLAN MAC, a 1T1R capable WLAN baseband, and RF in CMOS single chip, which are designed to meet both the low power and high throughput application. The AIC8800DW provides a complete solution for a high-performance integrated wireless device. This documentation describes the engineering requirements specification.

SKI.W800DWU.1 是一个基于 AICSEMI AIC8800DW 方案的 WiFi 模组，符合 IEEE 802.11b/g/n/ax，频段 2.4-2.5GHz。

模块的硬件体系结构如图 1 所示。它在 CMOS 单片机中集成了 WLAN MAC、1T1R 能力的无线局域网基带和 RF，旨在满足低功耗和高吞吐量的应用。AIC8800DW 为高性能集成无线通信提供了完整的解决方案，本文档描述工程需求规范。

2. Features (特性)

Protocol 支持标准	IEEE Std. 802.11b
	IEEE Std. 802.11g
	IEEE Std. 802.11n
	IEEE Std. 802.11ax
Chip Solution 芯片方案	AIC8800DW
Band 波段	2.4GHz
Dimensions 尺寸	12.7*12.3*2.45
Antenna 天线	Stamp Hole*1
Installation Mode 安装方式	SMD
Remark 备注	

3. Block Diagram (结构框图)

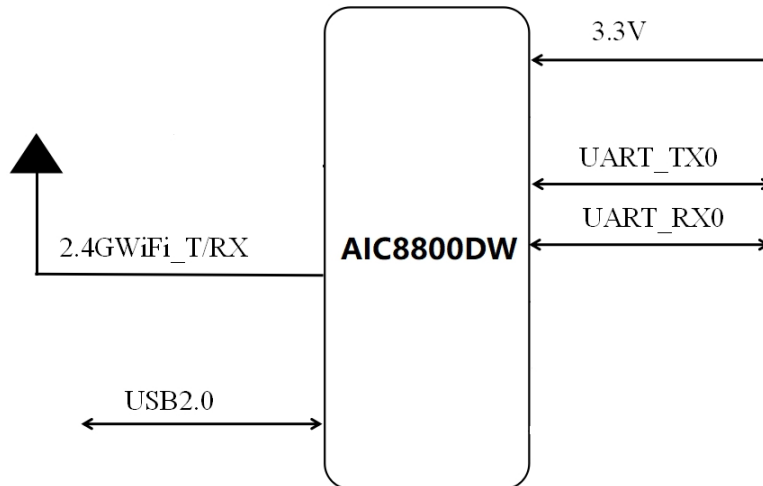

4. Package Outline and Mounting (外形及安装尺寸)

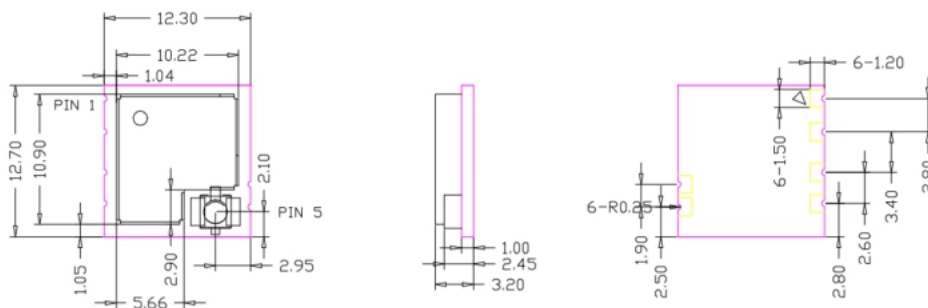

模组俯视图

模组侧视图

模组底视图

5. Pin Definition (引脚定义)

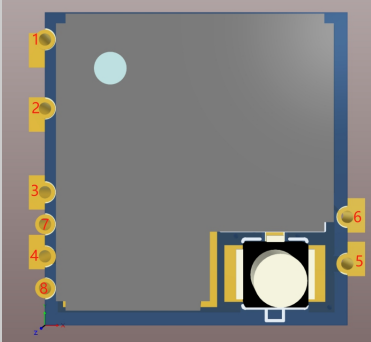

正视图

PIN	SYMBOL	DESCRIPTION
1	VBAT	3.3V Power supply\3.3V 供电
2	USB_DM	USB_2.0 DM 引脚
3	USB_DP	USB_2.0 DP 引脚
4	GND	Ground\地
5	GND	Ground\地
6	RF	2.4G WIFI
7	UART0_RX	Debug_UART
8	UART0_TX	Debug_UART

6. Product Pictures (实物图片)

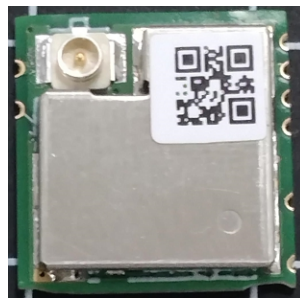

正视图 (top view)



背视图 (bottom view)

7. Key Materials (关键物料)

序号	关键件名称	型号	规格/材料	备注
1	集成电路	AIC8800DW	QFN36	
2	PCB	SKI.W800DWU.1	FR-4,2LAY	
3	晶体振荡器	CN4026M00012T2115181	26MHz	

8. General Requirements (一般要求)

No.	Feature	Description
8-1	Operation Voltage 工作电压范围	3.3V±0.3
8-2	Current Consumption 最大电流	600mA
8-3	Ripple 纹波	≤120mV@3.3v
8-4	Operation Temperature 工作温度范围	-10°C to +70°C
8-5	Antenna Type 天线类型	External antenna
8-6	Interface	High Speed USB 2.0 Interface
8-7	Storage Temperature 存储温度	-40°C to +85°C

9. Electrical Characteristics (电气特性)

除非另有说明，电气规范试验都在下列条件下进行：

环境条件温度：25°C ± 5°C；

电源电压：模块输入电压 3.3V (±10%)；

The Test for electrical specification was performed under the following condition unless otherwise specified.

Ambient condition Temperature :25°C ± 5°C；

Power supply voltages: 3.3V (±10%) input power at the Module；

9.1 IEEE 802.11b Section

Items	Contents				
Specification	IEEE802.11b				
Mode	CCK				
Channel	CH1 to CH13				
Data rate	1, 2, 5.5, 11Mbps				
TX Characteristics	Min.	Typ.	Max.	Unit	Remark
1. Power Levels at each rate (1Mbps~11Mbps)	15.0	17.0	19.0	dBm	
2. Spectrum Mask @ target power					
1) $f_c \pm 11\text{MHz}$ to $\pm 22\text{MHz}$	-	-	-30	dBr	
2) $f_c > \pm 22\text{MHz}$	-	-	-50	dBr	
3. Constellation Error(EVM)@ target power					
1) 1Mbps	-	-	-10	dB	
2) 2Mbps	-	-	-10	dB	
3) 5.5Mbps	-	-	-10	dB	
4) 11Mbps	-	-	-10	dB	
4. Frequency Error	-10	-	10	ppm	
RX Characteristics	Min.	Typ.	Max.	Unit	
5. Minimum Input Level Sensitivity (each chain)					
1) 1Mbps (FER $\leq 8\%$)	-	-	-83	dBm	
2) 2Mbps (FER $\leq 8\%$)	-	-	-80	dBm	
3) 5.5Mbps (FER $\leq 8\%$)	-	-	-79	dBm	
4) 11Mbps (FER $\leq 8\%$)	-	-	-76	dBm	
6. Maximum Input Level (FER $\leq 8\%$)	-10	-	-	dBm	

9.2 IEEE 802.11g Section

Items	Contents				
Specification	IEEE802.11g				
Mode	OFDM				
Channel	CH1 to CH13				
Data rate	6, 9, 12, 18, 24, 36, 48, 54Mbps				
TX Characteristics	Min.	Typ.	Max.	Unit	Remark
1、Power Levels at each rate (6M~54M)	13.0	15.0	17.0	dBm	
2. Spectrum Mask @ target power					
1) at $f_c \pm 11\text{MHz}$	-	-	-20	dBr	
2) at $f_c \pm 20\text{MHz}$	-	-	-28	dBr	
3) at $f_c > \pm 30\text{MHz}$	-	-	-40	dBr	

3. Constellation Error(EVM)@ target power					
1) 6Mbps	-	-	-5	dB	
2) 9Mbps	-	-	-8	dB	
3) 12Mbps	-	-	-10	dB	
4) 18Mbps	-	-	-13	dB	
5) 24Mbps	-	-	-16	dB	
6) 36Mbps	-	-	-19	dB	
7) 48Mbps	-	-	-22	dB	
8) 54Mbps	-	-	-25	dB	
4. Frequency Error	-10	-	10	ppm	
RX Characteristics	Min.	Typ.	Max.	Unit	
5. Minimum Input Level Sensitivity (each chain)					
1) 6Mbps (PER \leq 10%)	-	-	-85	dBm	
2) 9Mbps (PER \leq 10%)	-	-	-84	dBm	
3) 12Mbps (PER \leq 10%)	-	-	-82	dBm	
4) 18Mbps (PER \leq 10%)	-	-	-80	dBm	
5) 24Mbps (PER \leq 10%)	-	-	-77	dBm	
6) 36Mbps (PER \leq 10%)	-	-	-73	dBm	
7) 48Mbps (PER \leq 10%)	-	-	-69	dBm	
8) 54Mbps (PER \leq 10%)	-	-	-65	dBm	
6. Maximum Input Level (PER \leq 10%)	-20	-	-	dBm	

9.3 IEEE 802.11n HT20/40 Section(2.4GHz)

Items	Contents				
Specification	EEE802.11n HT20/40 @2.4GHz				
Mode	OFDM				
Channel	HT20:CH1 to CH13 HT40:CH3 to CH11				
Data rate (MCS index)	MCS0/1/2/3/4/5/6/7				
TX Characteristics	Min.	Typ.	Max.	Unit	Remark
1. Power Levels at each rate (MCS0~ MCS7)	13.0	15.0	17.0	dBm	
2. Spectrum Mask @ target power					
1) at $f_c \pm 11\text{MHz}$	-	-	-20	dBr	
2) at $f_c \pm 20\text{MHz}$	-	-	-28	dBr	
3) at $f_c > \pm 30\text{MHz}$	-	-	-45	dBr	
3. Constellation Error(EVM)@ target power					
1) MCS0	-	-	-5	dB	
2) MCS1	-	-	-10	dB	

3) MCS2	-	-	-13		dB	
4) MCS3	-	-	-16		dB	
5) MCS4	-	-	-19		dB	
6) MCS5	-	-	-22		dB	
7) MCS6	-	-	-25		dB	
8) MCS7	-	-	-28		dB	
4. Frequency Error	-10	-	10		ppm	
RX Characteristics	Min.	Typ.	Max.		Unit	
5. Minimum Input Level Sensitivity (each chain)			HT20	HT40		
1) MCS0 (PER \leq 10%)	-	-	-82	-79	dBm	
2) MCS1 (PER \leq 10%)	-	-	-79	-76	dBm	
3) MCS2 (PER \leq 10%)	-	-	-77	-74	dBm	
4) MCS3 (PER \leq 10%)	-	-	-74	-71	dBm	
5) MCS4 (PER \leq 10%)	-	-	-70	-67	dBm	
6) MCS5 (PER \leq 10%)	-	-	-66	-63	dBm	
7) MCS6 (PER \leq 10%)	-	-	-65	-62	dBm	
8) MCS7 (PER \leq 10%)	-	-	-64	-61	dBm	
6. Maximum Input Level (PER \leq 10%)	-20	-	-		dBm	

9.4 IEEE 802.11ax HE20/40 Section(2.4GHz)

Items	Contents				
Specification	IEEE802.11ax HE20/40@2.4GHz				
Mode	OFDMA				
Channel	HE20:CH1 to CH13 HE40:CH3 to CH11				
Data rate (MCS index)	MCS0/1/2/3/4/5/6/7/8/9				
TX Characteristics	Min.	Typ.	Max.		Unit
1.Power Levels at each rate (MCS0~ MCS9)	13.0	15.0	17.0		dBm
2. Spectrum Mask @VHT20/VHT40/VHT80 target power					
1) at fc +/-11MHz/21MHz/41MHz	-	-	-20		dBr
2) at fc +/-20MHz/40MHz/80MHz	-	-	-28		dBr
3) at fc +/-30MHz/60MHz/120MHz	-	-	-40		dBr
3. Constellation Error(EVM)@ target power					
1) MCS0	-	-	-5		dB
2) MCS1	-	-	-10		dB
3) MCS2	-	-	-13		dB
4) MCS3	-	-	-16		dB
5) MCS4	-	-	-19		dB

6) MCS5	-	-	-22	dB	
7) MCS6	-	-	-25	dB	
8) MCS7	-	-	-27	dB	
9) MCS8	-	-	-30	dB	
10) MCS9	-	-	-32	dB	
4. Frequency Error	-10	-	10	ppm	
RX Characteristics	Min.	Typ.	Max.	Unit	
5. Minimum Input Level Sensitivity (each chain)			HE20	HE40	
1) MCS0 (PER ≤10%)	-	-	-82	-79	dBm
2) MCS1 (PER ≤10%)	-	-	-79	-76	dBm
3) MCS2 (PER ≤10%)	-	-	-77	-74	dBm
4) MCS3 (PER ≤10%)	-	-	-74	-71	dBm
5) MCS4 (PER ≤10%)	-	-	-70	-67	dBm
6) MCS5 (PER ≤10%)	-	-	-66	-63	dBm
7) MCS6 (PER ≤10%)	-	-	-65	-62	dBm
8) MCS7 (PER ≤10%)	-	-	-64	-61	dBm
9) MCS8 (PER ≤10%)	-	-	-59	-56	dBm
10) MCS9 (PER ≤10%)	-	-	-57	-54	dBm
6. Maximum Input Level (PER ≤10%)	-30	-	-	-	dBm

10. Reference Design (参考设计)

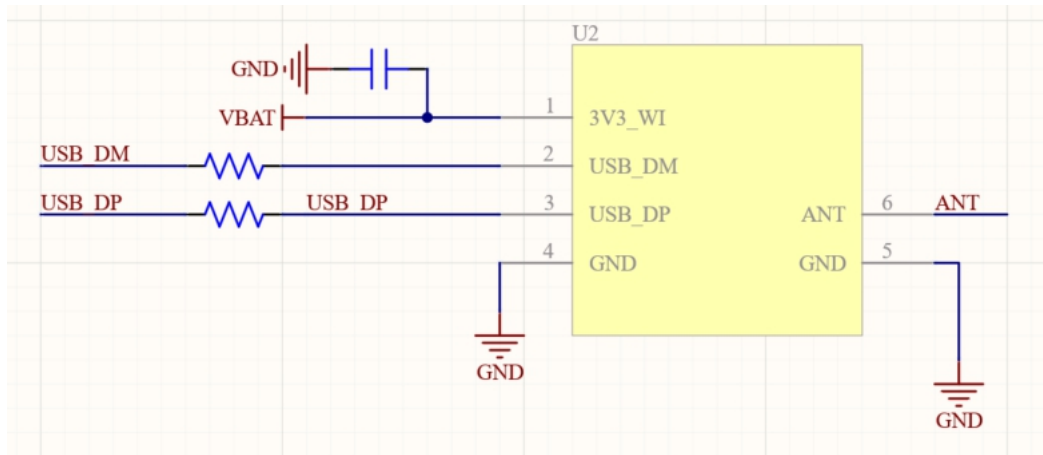

注意事项:

1. 射频线需按照 50Ω控制阻抗。
2. 靠近射频断开的 GND PIN 引脚需保证良好接地（建议用直接铺地的方式铺铜）。
3. 为了方便调节射频性能，射频接口与天线之间需预留π型匹配电路，此π电路需靠近天线放置，根据实际情况进行规格选型。当天线阻抗失配时，可通过此电路进行匹配调试。
4. RF 走线要尽可能短，且避免直角和锐角走线。
5. 两路射频天线接口需要尽量拉远，之间打满两排以上地孔以增加隔离度。

6.VBAT 网络在靠近模组端放置两颗 10uF 电容.

11. Mechanical, Environmental and Reliability Tests

(机械、环境和可靠性测试)

Test Items		Test Conditions	Qty	Criteria Condition
11-1	Drop test	The packed samples within 100Kg can be tested Drop height: Face Side: 800/600/450mm Edge line: 600/450/350mm Drop time: 1 each Face and edge.	1xBox	After drop test, the outer box and inner box will not be broken by appearance visual inspection.
11-2	Vibration test	X-Y-Z direction, first Frequency changing from 10Hz to 30Hz to 10Hz, amplitude 0.75mm, 5 times vibrations, then frequency Changing from 30Hz to 55 Hz to 30 Hz, amplitude 0.15mm, 5 time vibration.	3	After test, the Appearance, Power EVM and Frequency error shall be satisfied with the specification.
11-3	Impact test	Impact acceleration: 50m/sec ² ; Impact duration: 16ms; Impact times: 1000.	3	After test, the Appearance, Power EVM and Frequency error shall be satisfied with the specification.
11-4	Soldering ability test	Soldering temperature: 235±5℃ Soldering duration: 2±0.5S	3	1.After soldering, the soldered area must be covered by a smooth bright solder layer, some deficiencies such as a small amount of the pinhole, not wetting are allowed, but the deficiencies can not be in the same place; 2.At least 90% of soldered area shall be covered continuously by the soldering material.
11-5	Humidity test	Leave samples in 40±3℃, 93% RH @ 96 hours	3	Leave samples in standard test condition for 2 hours then test, the Appearance, Power, EVM and Frequency error functional parameter shall be satisfied with the test specification.
11-6	High temperatur	Thermostat cabinet	60	After test, leave samples in standard condition for 1 hour and test, Power, EVM

	e load life test	temperature: 55±5℃ Applied voltage: 110% rated voltage Working duration: 200 hour (Supply Voltage Cycle 23h power on, 1h power off)		and Frequency error shall be satisfied with the test specification.
11-7	High temperature load test	Temperature: 55±5℃ Samples work for 16 hours	3	After test, the Appearance, Power, EVM and Frequency error shall be Satisfied with the test specification.
11-8	Low temperature storage test	Leave the samples in -25±3℃@24 hours	3	Leave samples in standard test condition for 2 hours then test, the Appearance, Power, EVM and Frequency error shall be satisfied with the test specification.
11-9	Low temperature load test	Leave samples in -15±3℃@ 2 hours, samples' function shall be normal, the let samples work for 1 hour	3	After test, leave the samples in standard condition and tested the Appearance, Power, EVM and Frequency error shall be satisfied with the test specification.
11-10	Temperature circle test	One cycle duration -10±3℃@3H 40±3℃ @3H Total cycle: 10x	3	After test, leave the samples in standard condition and tested Power EVM and Frequency error shall be qualified and all the characters shall be satisfied with the test specification.
11-11	Continuous TP test	Twice cycle duration -10±3℃@4H +60±3℃@4H, +25@2H@2H	3	During test, There will not been appeared signal disconnection or interruption between DUT and AP.
11-12	ESD	Discharge voltage: 1kV C: 150pF Discharge resistance: 330Ω Positive10 times 1 time for each second	3	The products can recoverable smoothly after ESD test.

12. Package (包装)

(1) 编带包装示意图

卷带进料方式 (箭头代表编带包装进料方向) :

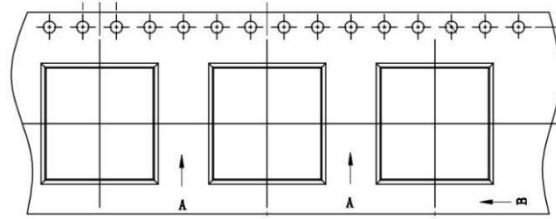

(2) 编带方向

(3) 外箱图纸示意图

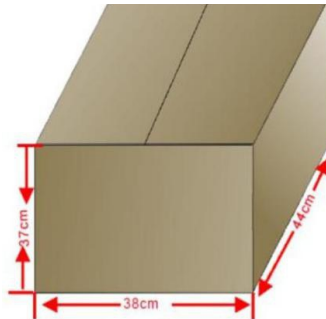

(4) 包装要求信息

13.Storage and Production (存储、生产)

13.1 Storage requirements (存储要求)

本产品的湿敏特性为 3 级 (MSL3)，出厂时以真空密封袋包装。产品搬运、存储、加工过程必须遵循 IPC/JEDEC J-STD-033。

在环境温度 $23 \pm 3^{\circ}\text{C}$ ，空气湿度小于 65% 的情况下，真空包装可存放 12 个月。为了确保焊接良率，模组拆封后，在环境温度低于 30 摄氏度，空气湿度小于 60% 的情况下 168 小时以内完成贴片，若烘烤后暴露时间大于 168 小时没有使用完，需要再次进行烘烤后上线。烘烤后自然条件下冷却到 36°C 以下后，可以再次正常上线。若暴露时间超过 168 小时未经过烘烤，不建议使用回流焊或者波峰焊工艺焊接此批次模组，因为模组的湿敏等级是 3 级，超过允许的暴露时间产品会发生受潮，进行高温焊接时可能会导致器件失效或焊接不良。如不满足上述条件需要进行烘烤，烘烤参数如下表。

表 18-1 烘烤参数

温度	烘烤条件	烘烤时间	
60±5℃	湿度≤5%RH	48 小时	卷盘
125±10℃	湿度≤5%RH	12 小时	耐高温托盘包装

13.2 Production parameters (生产参数)

钢网厚度建议为 0.15mm~0.18mm，常用 0.15mm 厚度。

炉温最高不能超过 250℃，推荐是 245℃。

推荐 SMT 焊炉温曲线如下图所示。



图 12-1 炉温曲线推荐图 (Tp=245℃, TL=220℃)

表 12-2 炉温曲线参数

炉温参数	最小值	典型值	最大值	单位
预热区最低温度 Tsmmin	150			℃
预热区最高温度 Tsmmax			200	℃
预热上升时间 ts	60		120	s
回流焊区升温速率(TL 到 Tp)			3	℃/s
回流焊区低温 TL		220		℃
回流焊区峰值温度 Tp		245	250	℃
回流焊峰值温度时间 tp(Tp 波动 5℃ 范围)			30	s
回流焊区冷却降温速率 (Tp 到 TL)			6	℃/s
回流时间 t	40		60	s

本产品的型号核准代码标识在产品后标牌上。

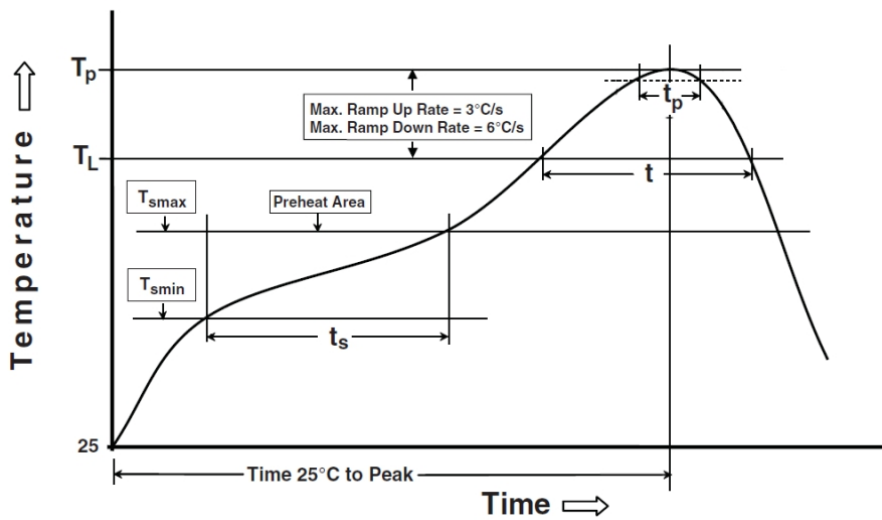
模块通过型号核准并不代表嵌入或使用该模块的最终设备符合相关无线电管理技术规定或

标准，最终设备厂商须对产品的技术特性是否符合无线电管理技术规定或标准负责。